

DigMe: Digital Microelectronics

Naoki Pross – naoki.pross@ost.ch

Fall Semester 2021

Contents

1 License	i
2 Introduction to SoC	1
2.1 Xilinx Zynq-7000 Family SoCs	1
3 Design Flow	1
4 Design constraints and static timing analysis (STA)	1
4.1 Physical constraints	1
4.2 Timing constraints	1
4.3 XDC file format	1
4.3.1 Specify properties	1
4.3.2 Create clocks	1
4.3.3 Add nonidealities	2
5 System level VHDL	2
5.1 Aliases	2
5.2 Generics	2
5.3 Generators	2
5.4 Functions and procedures	2
5.5 Arrays and records	2
5.6 Packages	3
5.7 Fixed point arithmetic	3
5.7.1 Mathematics	3
5.7.2 Manual implementation	3
5.7.3 With VHDL 2008 <code>fixed_pkg</code>	3
5.8 Block RAM	4
6 Intellectual Property (IP) Blocks	4
7 Serial communication	4
7.1 Classification	4
7.2 Logic to physical signal conversion	4
7.3	4

1 License

This work is licensed under a [Creative Commons “Attribution-NonCommercial-ShareAlike 4.0 International”](https://creativecommons.org/licenses/by-nc-sa/4.0/) license.



2 Introduction to SoC

A system on chip (SoC) is a “complete” system that includes

- a microprocessor, memory, peripherals and
- application specific blocks (IP blocks).

SoCs can be made in FPGAs, which has the following advantages:

- Shorter development cycles
- Lower development cost
- Lower total cost for low to medium volume
- More flexibility in operation (updates, etc.)

2.1 Xilinx Zynq-7000 Family SoCs

The Zynq-7000 AP SoC architecture consists of two major sections and some analog extensions. It has

- a Processing System (PS) with an ARM Cortex-A9 (up to 1 GHz),
- a Programmable Logic (PL), and
- an analog / mixed signal block with 2 12-bit ADCs at 1 MS/s.

The PL is built like and FPGA from the Xilinx Series 7 device. The PL is made of an array of blocks (CLB) and switch matrices. Each CLB has 2 slices, and each slice has 4 look up tables (LUT). Each LUT has 6 inputs / outputs, a carry logic, a multiplexer, and 8 flip-flops. Depending on the structure, up to 4 flip-flops can be used as latches.

3 Design Flow

4 Design constraints and static timing analysis (STA)

Synthesis and implementation tools can reduce VHDL code into a set of combinatoric and sequential logic parts, but for the last step information about the hardware is required. Such information is given through the *constraints* defined through XDC¹ or SDC² files. Both file formats are mostly a set of TCL commands.

Constraints should be generally organized in three sections (or separate files):

- Physical constraints: described below, usually before timing.
- Timing assertions: primary clocks, virtual clocks, generated clocks, clock groups, input and output delay constraints.
- Timing exceptions: false paths, min / max delay, multicycle paths, case analysis, disable timing.

¹Xilinx Design Constraints, proprietary format.

²Synopsys Design Constraints, industry standard.

4.1 Physical constraints

Physical constraints include: I/O constraints, Netlist constraints, Placement constraints, Routing constraints. Physical constraints are usually given through the graphical user interface.

In the VIVADO IDE under the package view, multifunction pins display as part of the I/O bank they are contained in, and display with symbols representing their available functions. For example:

- Basic I/O pins display as *gray circles* by default.
- Clock capable pins display as *blue hexagons* by default.
- VREF, VRP, and VRN pins display with a *small power icon* by default.
- The remaining pins display with an asterisk (*) and are not displayed by default.

4.2 Timing constraints

$$t_{\text{slack}} = T - t_{\text{arrival}}$$

4.3 XDC file format

XDC files are basically a set of TCL commands. A command takes some arguments, and if the argument starts with a dash ‘-’ it’s an option. Curly brackets ‘{ }’ are used to group things. Commands can be nested using square brackets ‘[]’ (executes what is in the brackets and give it to the outer command). Comment lines start with a ‘#’, long lines are extended with ‘\’.

4.3.1 Specify properties

```
1 set_property <property> <hw> \
2   [get_ports <pin>]

1 set_property PACKAGE_PIN Y19 \
2   [get_ports x[1]]
3 set_property IOSTANDARD LVCMOS33 \
4   [get_ports clk]
5 set_property PULLTYPE PULLUP \
6   [get_ports nreset]
```

4.3.2 Create clocks

To create primary clocks, that is it enters the design through an input port or a gigabit transceiver output pin (clock recovery), the following command is used:

```
1 # rise and fall time in ns
2 create_clock -period <T> \
3   -name <name> -waveform {<rise> <fall>} \
4   [get_ports <pin>]
```

It is also possible to create generated clocks, that are associated to a master (primary or another generated) clock. A generated clock may perform an operation on its master clock, examples are: period division or multiplication (or both) and phase shift. For example to divide and invert a clock sysclk:

```

1 create_generated_clock -name devclk \
2   -divide_by 2 -invert -master_clock \
3   -source [get_clocks sysclk] \
4   [get_pins out]

```

Virtual clocks, which do not physically exist, but may be useful as theoretical references or for testing, can be created by omitting the source argument for a primary clock:

```
1 create_clock -name virtclk -period 10
```

4.3.3 Add nonidealities

5 System level VHDL

5.1 Aliases

The goal is now to build re-usable intellectual property (IP) blocks with VHDL. For that we need to refresh some important features of the language. The first of which are aliases.

```

1 signal data_bus :
2   std_logic_vector(31 downto 0);
3 alias first_nibble :
4   std_logic_vector(0 downto 3)
5   is data_bus(31 downto 28);

```

5.2 Generics

5.3 Generators

Another useful feature are `generate` statement, with the syntax that allows the instantiation of multiple components.

```

1 [label]: for <identifier> in <range> generate
2   -- optional declaration part
3   -- begin only required if there is a
4     ↳ declaration
5 [begin]
6   -- concurrent statements
7 end generate [label];

```

For example:

```

1 for i in 0 to 7 generate
2   x(i) <= a(i) xor b(7 - i);
3 end generate;

```

Or in a more realistic case, with components imported from elsewhere.

Listing 1: Example of generate with a component.

```

1 -- in architecture
2 bcd_to_sseg_inst:
3 for i in 0 to nr_digits - 1 generate
4   bcd_to_sseg_inst: component bcd_to_sseg
5     port map(
6       clk => clk,
7       rst => rst,
8       bcd => bcd_array(i),
9       sseg => sseg_array(i)
10    );
11 end generate;

```

where `bcd_array` and `sseg_array` are of course array types, and `nr_digits` is a constant.

5.4 Functions and procedures

Furthermore VHDL has functions that can be useful to avoid rewriting the same code. Function have multiple inputs and a signal output, are allowed to be called recursively, but cannot declare or assign signals, nor use `wait` statements.

```

1 function <name> ([list of arguments with type])
2   return <return type>
3 is
4   [declaration of variables]
5 begin
6   -- sequential statement (but not wait)
7 end function <name>;

```

An example is a parity generator:

Listing 2: An odd parity generator function.

```

1 function pargen(avect: std_ulogic_vector)
2   return std_ulogic
3 is
4   variable po_var : std_logic;
5 begin
6   po_var := '1';
7   for i in avect'range loop
8     if avect(i) = '1' then
9       po_var := not po_var;
10    end if;
11  end loop;
12  return po_var;
13 end function pargen;

```

In testbenches it is common to see procedures. They differ for function as they can have multiple inputs and *multiple output*. Because of this they in practice are usually not synthesizable. The syntax is similar to functions:

```

1 procedure <name> ([list of arguments with
2   direction]) is
3   [declaration of variables]
4 begin
5   -- sequential statement
6 end procedure <name>;

```

With *list of arguments with direction* it is meant an expression like `a, b : in real; w : out real`, similar to the arguments of `port`.

5.5 Arrays and records

To efficiently use `generate` statement, such as in listing 1, we need array types. Arrays types (fields) of other types are defined with the following syntax.

```
1 type <name> is array (<upper
2   limit> downto <lower limit>) of <base type>;
```

For example to complete listing 1, we create 1 by 1 matrices.

```

1 constant nr_digits : integer := 3;
2 type bcd_array_type is

```

```

3  array (0 to nr_digits -1)
4  of std_ulogic_vector(3 downto 0);
5  type bcd_array_type is
6  array (0 to nr_digits -1)
7  of std_ulogic_vector(6 downto 0);

```

While all arrays elements must have the same underlying type, *records* allow for different types to be combined together. For example:

```

1  type memory_access is record
2  address : integer range 0 to
      ↪ address_max -1;
3  mem_block : integer range 0 to 3;
4  data : std_ulogic_vector(word_width -1
      ↪ downto 0);
5  end record;

```

5.6 Packages

To declare your own packages, the syntax is rather easy:

```

1  <library and / or use statements>
2  package <name> is
3  [declarations]
4  end package <package name>;

```

And possibly in another file the implementation is given with:

```

1  package body <name> is
2  <list of definitions>
3  end package body <name>;

```

In practice it is common to see for example a configuration package, that contains all constants for the project. For example if we were to put the function `pargen` from listing 2 we could do:

```

1  package parity_helpers is
2  constant nibble : integer;
3  constant word   : integer;
4  function pargen(avect :
      ↪ std_ulogic_vector) return
      ↪ std_ulogic;
5  end package parity_helpers;
6
7  package body parity_helpers is
8  -- functions
9  function pargen(avect :
      ↪ std_ulogic_vector)
10     return std_ulogic
11  is ...same as listing 2 ...
12  end function pargen;
13  -- instantiation of variables
14  constant nibble : integer := 4;
15  constant word   : integer := 8;
16  end package body parity_helpers;

```

And later use it with `use work.parity_helpers.all`.

5.7 Fixed point arithmetic

5.7.1 Mathematics

Recall that a binary number is represented using weights ‘bits’ $a_k \in \{0, 1\}$ in front of powers of 2, so that an in-

teger $z \in \mathbb{N}_0$ is represented with n bits as

$$z = \sum_{k=0}^{n-1} a_k 2^k.$$

Thus with n bits we can represent the integer range $\{0, \dots, 2^{n-1}\}$. To expand this to negative integers we shift everything by 2^k obtaining

$$z = -(2^{n-1})a_{n-1} + \sum_{k=0}^{n-2} a_k 2^k,$$

which allows for values in the asymmetric integer range $\{-2^{n-1}, \dots, 2^{n-1} - 1\}$. To further extend this to the rational numbers we add to the n integer bits, m fractional bits, such that

$$z = \sum_{k=-m}^{n-1} a_k 2^k.$$

This format is known as the `Qn.m` or $Q(n, m)$ format. It is however not specified if the values are to be interpreted as signed or unsigned. For that there are: `uQn.m` for unsigned values which has range 0 to $2^n - 2^{-m}$, and `sQn.m` for signed values with range -2^{n-1} to $2^{n-1} - 2^{-m}$ (same as previous but shifted by 2^n).

When doing calculations using `Qn.m` with different sizes, generally the following rules apply:

$$\begin{aligned} Q(n_1, m_1) + Q(n_2, m_2) \\ &= Q(\max(n_1, n_2) + 1, \max(m_1, m_2)) \\ Q(n_1, m_1) \cdot Q(n_2, m_2) &= Q(n_1 + n_2, m_1 + m_2) \end{aligned}$$

There is an edge case for products between `sQn.m` numbers where we can save a bit using

$$\begin{aligned} Q_s(n_1, m_1) \cdot Q_s(n_2, m_2) \\ &= Q_s(n_1 + n_2 - 1, m_1 + m_2 + 1) \end{aligned}$$

5.7.2 Manual implementation

To manually implement fixed point arithmetic in VHDL, we can use `integer` types by left shifting the numbers by the right amount. For example:

```

1  constant A : real = 2.5248;
2  -- convert this into a uQ2.6 (8 bits)
3  -- we have to left shift by 2^6.
4  variable a_fix : unsigned(7 downto 0) :=
5  to_unsigned(integer(2.0 ** 6 * A), 8);
6  -- Note that by keeping only 6 digits
7  -- the value is truncated down to 2.5156

```

5.7.3 With VHDL 2008 fixed_pkg

In VHDL 2008 there is a fixed point arithmetic library, which is unfortunately not completely standardized yet. It is not always optimum in terms of resource usage and speed because it guarantees overflow prevention. To import it we simply add the following:

```

1 -- since VHDL 2008
2 library ieee;
3 use ieee.fixed_generic_pkg.all;
4 use ieee.fixed_float_types.all;

1 -- older versions
2 library ieee_proposed;
3 use ieee_proposed.fixed_pkg.all;
4 use ieee_proposed.fixed_float_types.all;

```

To represent $uQ_n.m$ numbers the syntax is:

```
1 signal f : ufixed(<n> downto -<m>);
```

The minus sign implies that the values are after the comma. To write $sQ_n.m$ numbers there is the type `sfixed`. Actually any range is valid, so it is possible to write:

```
1 signal f : ufixed(-2 downto -3);
```

Conversion operators `to_ufixed`, `to_sfixed` are available. To get back n and m the attributes 'high resp. 'low are available. Furthermore the library allows to control the behaviour of conversions and range limits, through arguments of `to_ufixed` (or `to_sfixed`).

- Overflow is controlled with `overflow_style` set to `fixed_saturated` (default, value cannot increase / decrease) or `fixed_wrap` (over / underflow).
- Rounding can be controlled by setting `round_style` to `fixed_round` (default) or `fixed_truncate`.

5.8 Block RAM

6 Intellectual Property (IP) Blocks

7 Serial communication

7.1 Classification

Serial communication protocols can be categorized by various criteria. From a network topology standpoint nodes can be connected as point to point (USART), star, bus (PCI), ring, mesh (IoT), fully connected, line, or tree. From a timing perspective a communication link can be either synchronous or asynchronous. The hardware interface can be serial or parallel. The communication can be On-Chip or Off-Chip. And finally, physically the electrical signal representing bits can be single ended, differential, voltage mode, or current mode.

Of the well known Open System Interconnect (OSI) model, which is composed of seven layers (from top to bottom): application, presentation, session, transport, network (packet), data-link (frame), physical (bit stream), in this course we will only care about the bottom 2, namely data-link and physical.

7.2 Logic to physical signal conversion

7.3

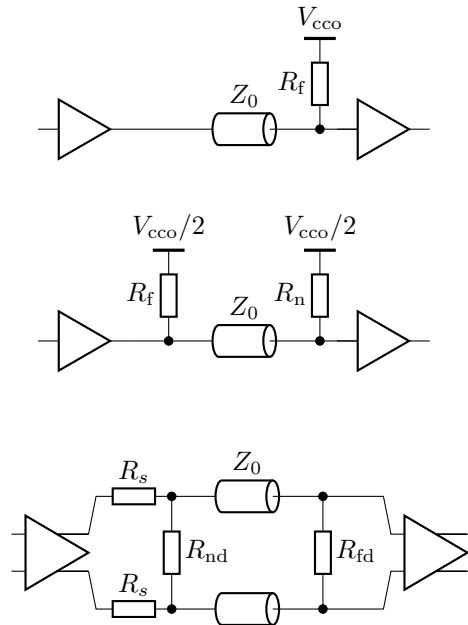

Figure 1: